

Signet 2350 Temperature Sensor



3-2350.090-1 Rev. G 9/06

English

Safety Instructions

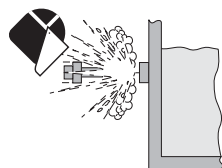

1. Prior to installation or removal:
 - Depressurize and vent system
 - Drain below sensor level
2. Confirm chemical compatibility before use.
3. Do not exceed maximum temperature/pressure specifications.
4. Wear safety goggles or faceshield during installation/service.
5. Do not alter product construction.
6. Dispose of properly; DO NOT INCINERATE!

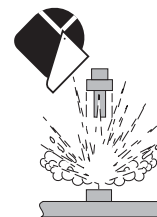

Table of Contents

1. Description
2. Specifications
3. Installation
4. S³L™ wiring
5. 4 to 20 mA wiring
6. 4 to 20 mA span adjustment
7. Ordering information

1. Description

The 2350 Temperature Sensor has a one-piece injection molded PVDF body that is ideal for use in high purity applications. It also outlasts metal sensors in aggressive liquids and eliminates the need for costly custom thermowells. These sensors are available with S³L™ digital output or field-scaleable 4 to 20 mA output. Dual threaded ends (3/4 in. NPT) allow submersion in process vessels, or in-line installation with conduit connection. Integral adapters (sold separately) may be used to create a compact assembly with field mount versions of the 8350 Temperature Transmitter.

2. Specifications

Compatibility

	509T	8350	8900
2350-1, -2	•	•	•
2350-3	•		

General

Wetted material: PVDF
 Measurement range:
 • In-line installation: -10°C to 100°C (14°F to 212°F)
 • Submersible installation: -10°C to 85°C (14°F to 185°F)
 Response time, τ: 10 s
 Process connection: 3/4 in. NPT male thread
 Rear connection: 3/4 in. NPT male thread
 Cable type: 3 cond + shield, 22 AWG
 Black/Red/White/Shield

Standard cable length:

•2350-1, -3: 4.6 m (15 ft.)
 •2350-2: 16 cm (6 in.)
 Shipping weight: .22 kg (0.5 lb)

Electrical

Power requirements:
 •S³L models: 5 VDC ±10%, <1.5 mA
 •4-20 mA models: 12-24 VDC ±10%
 Short circuit & reverse polarity protected

S³L™ output: Serial ASCII, TTL level 9600 bps
 •Accuracy: ±0.5°C (±0.9°F)
 •Repeatability: ±0.1°C (±0.2°F)
 •Resolution: 0.01°C (0.02°F)
 •Update rate: <100 ms

4-20 mA output:
 •Accuracy: ±0.5% of full scale
 •Repeatability: ±0.1°C (±0.2°F)
 •Resolution: <5 µA
 •Span: Factory set 4 to 20 mA = 0°C to 100°C, Field-scaleable.
 •Max loop impedance: 50Ω @ 12 V
 325Ω @ 18 V
 600Ω @ 24 V
 •Update rate: <100 ms

Dimensions

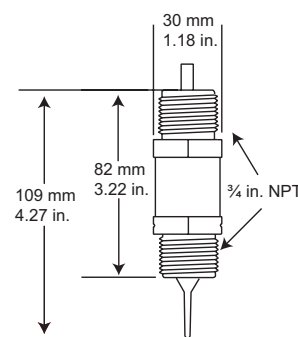

Environmental

Relative humidity: 0 to 95% (Non-condensing)
 Storage temperature: -55°C to 100°C (-67°F to 212°F)

Application Limits

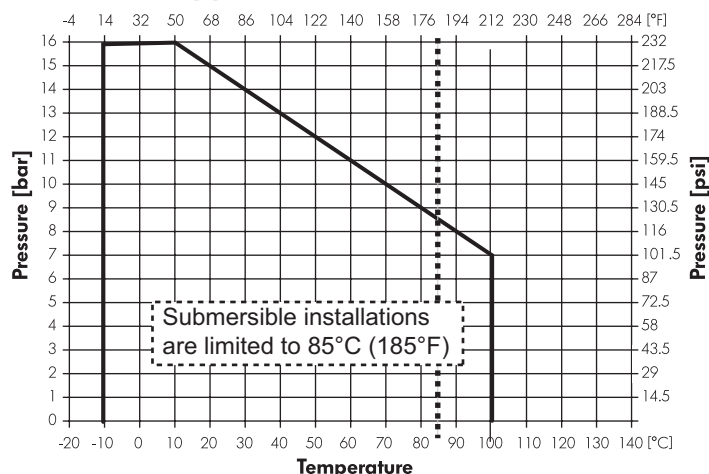

Approvals & Standards

- CE
- EN 61326-2 Heavy Industry Immunity
- EN 55011 Class A Heavy Industry Emissions
- Manufactured under ISO 9001 and ISO 14001

3. Installation

3.1 2350-2 Integral Assembly

The 3-8052 Integral Kit connects the 8350 Temperature Transmitter directly onto the 2350 sensor.

- Use the 2350-2 sensor with 6 in. cable and S³L™ output.
- The 3-8052 Integral kit includes:
 - 3/4 in. NPT process connection
 - 3-9000.392-1 liquid tight connector, 1/2 in. NPT
 - Conduit base to attach 8350.
- Apply sealant or PTFE tape to the process connection threads, after inspecting threads to ensure integrity. Do not install a sensor with damaged threads.
- Tighten the sensor 1 1/2 turns past finger tight into the process connection.

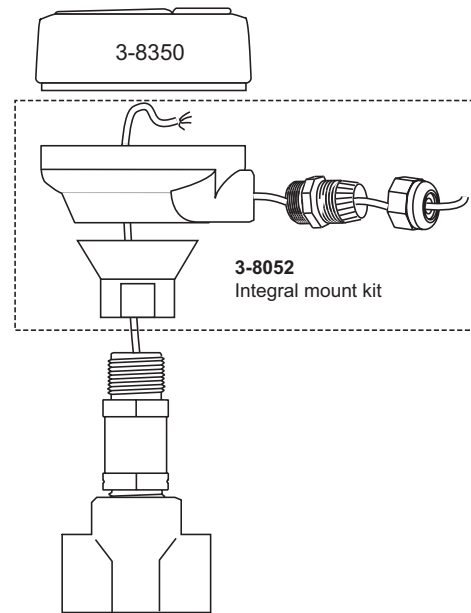

3.2 2350-2 or 2350-3 In-line Remote Assembly

The optional 3-8052-1 Integral Junction box with 3/4 in. process connection offers a convenient terminal point to extend the 2350 cable over a distance.

- The kit includes:
 - 3/4 in. NPT process connection
 - Conduit base and cap with junction terminals
 - 3-9000.392-1 liquid tight connector, 1/2 in. NPT
- Apply sealant or PTFE tape to the process connection threads, after inspecting threads to ensure integrity. Do not install a sensor with damaged threads.
- Tighten the sensor 1 1/2 turns past finger tight into the process connection.

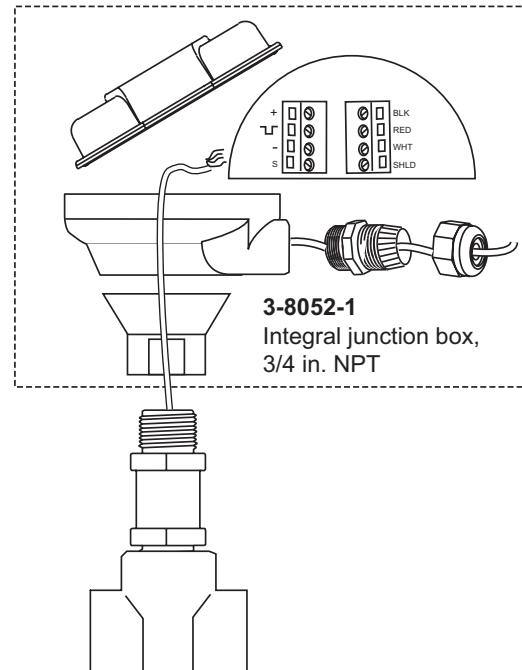

3.3 2350-1 or 2350-3 Submersible Installation

- Use the 2350-1 or 2350-3 sensor with 15 ft. cable.
- Mount the sensor to an extension pipe or watertight conduit using thread sealant.
- Use a cable gland at the top of the extension to prevent moisture intrusion/accumulation inside the pipe.
- For additional defense against possible accumulation of condensation at the back seal area of the sensor, fill the lower 3-4 inches (75-100 mm) of conduit or extension pipe with a flexible sealant such as silicone.
- The 8050-1 and the 8052-1 junction boxes can be useful accessories for this installation option.
- The fluid temperature must not exceed 85°C (185°F) in submersible installations.

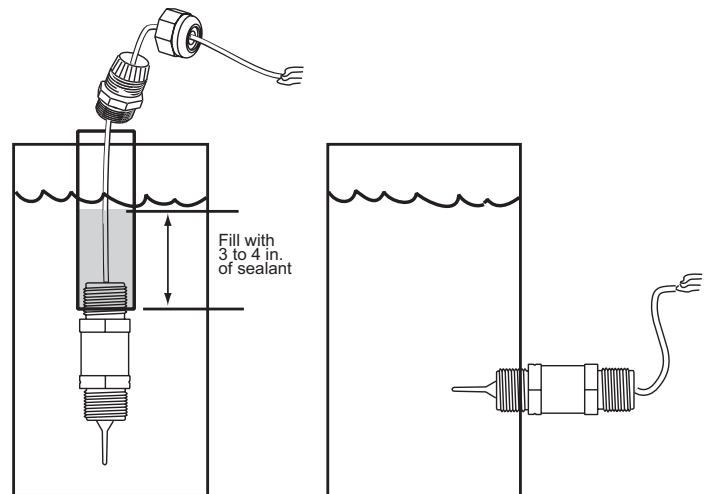

4. S³L™ Wiring

- All models of the 2350 provide S³L™ output when powered with 5 VDC.
- Connecting the SHIELD to a direct Earth ground may reduce electrical noise interference.
- The maximum S³L™ cable length is dependent upon the instrument to which the sensor is connected. Consult the instrument manual for details.

4.1 S³L™ With No Junction Box

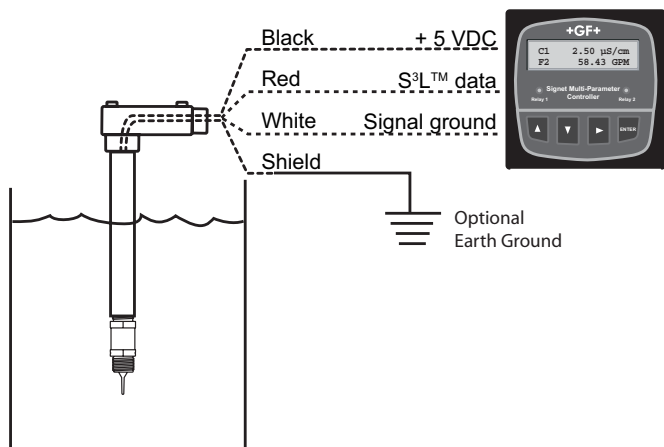

- Connect the 2350 cable directly to S³L I/O terminals.

4.2 S³L™ with Junction Box

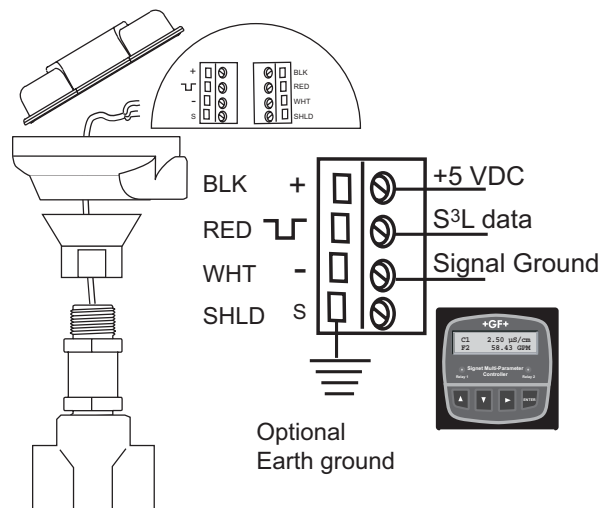

- When the 2350 includes a junction box, connect the 2350 terminals to any S³L™ I/O port as shown.

5. 4-20 mA Loop Wiring

- The 2350-3 provides a 4-20 mA loop output when powered with 24 VDC.
- Connecting the SHIELD to a direct Earth ground may reduce electrical noise interference.

5.1 Current Loop With No Junction Box

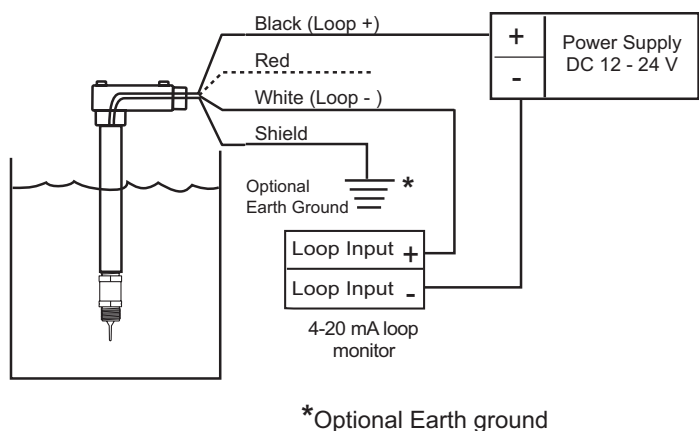

- Connect the 2350 cable directly to a loop device as shown.

5.2 Current Loop With Junction Box

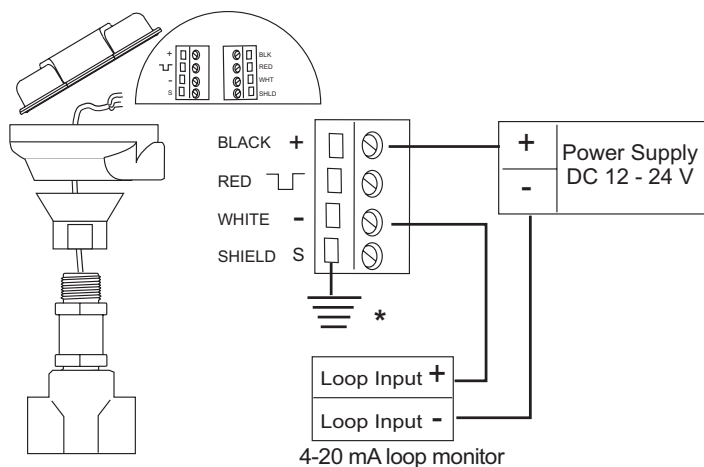

*Optional Earth ground

- When the 2350 includes a junction box, connect the 2350 terminals to a loop device as shown.

6. 4 to 20mA Span Adjustment

The 4 to 20 mA endpoint values are independent of one another and may be adjusted in the field. For example, to reduce the 20 mA endpoint value from the factory setting of 100°C, but to allow the 4 mA endpoint to remain at 0°C, perform only the steps listed in 6.2 below.

NOTE: The RED wire, which is not connected during normal 4 to 20 mA operation, assumes an important role in the following procedures.

6.1 To adjust the 4mA endpoint in the field:

- Expose the sensor to the temperature desired to correspond with 4 mA (-10°C to 100°C/85°C sumbersible).. (Be sure to allow sufficient time for the sensor to equilibrate to this temperature.)
- With power applied as described in Section 5, connect the RED wire to the WHITE wire for 15 seconds. (After about 10 seconds the output will drop to 3.6 mA and remain there until the RED wire is disconnected.)
- Disconnect the RED wire from the WHITE wire; the 4 mA endpoint has been adjusted.

NOTE: The output will act as a switch if the 4 and 20 mA endpoints are set very near to the same value.

6.2 To adjust the 20 mA endpoint in the field:

- Expose the sensor to the temperature desired to correspond with 20 mA (-10°C to 100°C/85°C sumbersible). (Be sure to allow sufficient time for the sensor to equilibrate to this temperature.)
- With power applied as described in Section 5, connect the RED wire to the BLACK wire for 15 seconds. (After about 10 seconds the output will rise to 22 mA and remain there until the RED wire is disconnected.)
- Disconnect the RED wire from the BLACK wire; the 20 mA endpoint has been adjusted.

NOTE: The output will act as a switch if the 4 and 20 mA endpoints are set very near to the same value. Minimum span is ±2% of maximum range.

6.3 To restore the factory setting:

- Disconnect power to the sensor. Wait 10 s for circuit to discharge.
- Connect the RED wire to the WHITE wire.
- Apply power as described in Section 5, but with the RED wire connected to the WHITE wire for 15 seconds. (After about 10 seconds the output will drop to 3.6 mA and remain there until the RED wire is disconnected.)
- Disconnect the RED wire from the WHITE wire; factory settings have been restored.

Mfr. Part No.	Factory Span
3-2350-3	4 to 20 mA = 0°C to 100°C

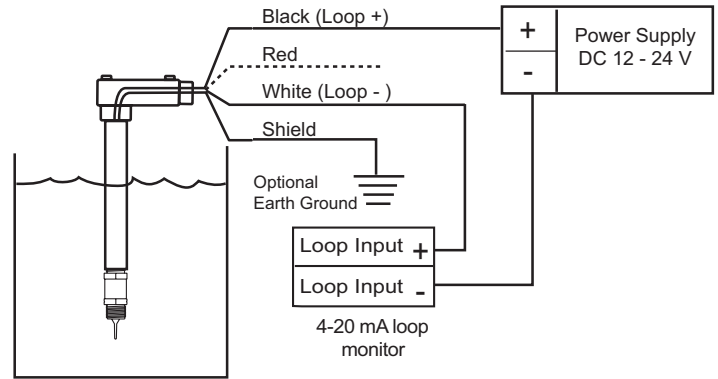

7. Ordering Information

Mfr. Part No.	Code	Description
3-2350-1	159 000 021	Temperature sensor, S ³ L™ output, 3/4 in. NPT, 4.6 m (15 ft.) cable
3-2350-2	159 000 022	Temperature sensor, S ³ L™ output, 3/4 in. NPT, 16 cm (6 in.) cable
3-2350-3	159 000 920	Temperature sensor, 4 to 20 mA output, 3/4 in. NPT, 4.6 m (15 ft.) cable

Accessories

Mfr. Part No.	Code	Description
3-8050-1	159 000 753	Universal mount junction box
3-8052	159 000 188	3/4 in. Integral mounting kit
3-8052-1	159 000 755	3/4 in. NPT mount junction box
3-9000.392-1	159 000 839	Liquid tight connector kit, NPT (1 piece)
3-9000.392-2	159 000 841	Liquid tight connector kit, PG13.5 (1 piece)
5523-0322	159 000 761	Cable, 3 conductor + shield, 22 AWG, black/red/white/shield

