

Signet 2507 Mini Flow Sensor



3-2507.090

Rev. L 02/07

English

WARNING! SAFETY INSTRUCTIONS



1. Do not remove from pressurized lines.
2. Confirm chemical compatibility before use.
3. Do not exceed maximum temperature/pressure specifications.
4. Wear safety goggles or faceshield during installation/service.
5. Do not alter product construction.
6. Failure to follow safety instructions could result in severe personal injury.

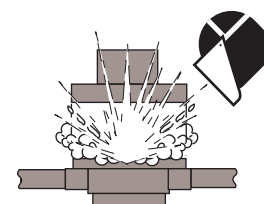

1. Description

The Signet 2507 Mini Flow Sensor contains a free-running rotor which is driven by the fluid flow. Within the given measurement range, the rotational speed of the rotor is proportional to the fluid flow rate. Permanent magnets built into the rotor actuate an electronic switch in the top of the sensor generating a square-wave output signal proportional to flow rate. Both opaque and transparent fluids can be measured from 0.2 to 20.0 centistokes.

Wetted sensor parts are constructed of PVDF and FPM, making the sensor suitable for use with most process fluids, including most acids, bases, light oils, and solvents.

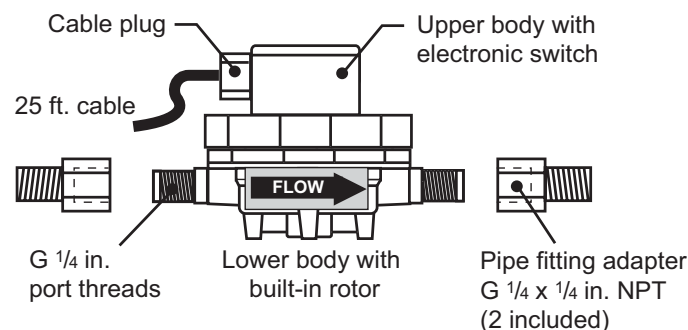

Polar organic solvents (i.e., ketones and chlorinated hydrocarbons) and aromatic hydrocarbons are not compatible with this sensor.

WARNING!

2. Specifications

General

- Compatibility: Signet 5075 Totalizing Monitor
 Signet 5500 Flow Monitor
 Signet 5600 Batch Controller
 Signet 8550 series Flow Transmitter
 Signet 8900 Multi-Parameter Controller
- Flow Range:
- -1V sensor: 100 to 2000 mL/m (0.026 to 0.528 U.S. gpm) (This sensor available in Europe only)
 - -2V sensor: 400 to 2800 mL/m (0.105 to 0.740 U.S. gpm)
 - -3V sensor: 700 to 4200 mL/m (0.185 to 1.123 U.S. gpm)
 - -4V sensor: 1300 to 6000 mL/m (0.343 to 1.585 U.S. gpm)
 - -6V sensor: 3200 to 12000 mL/m (0.845 to 3.170 U.S. gpm)
- Linearity: $\pm 0.25\%$ of full range
 Repeatability: $\pm 0.25\%$ of full range
 Viscosity range: 0.2 to 20.0 centistokes
 Pipe connections: G 1/4 in. ports, 1/4 in. NPT (male) pipe adapters (2 included)
- Cable length: Std: 7.6m (25 ft.), max.: 300 m (1000 ft.)
 Cable type: 2-conductor shielded, twisted-pair, 22 AWG
 Shipping Weight: 0.4 kg (0.8 lb.)

Pressure Drop:

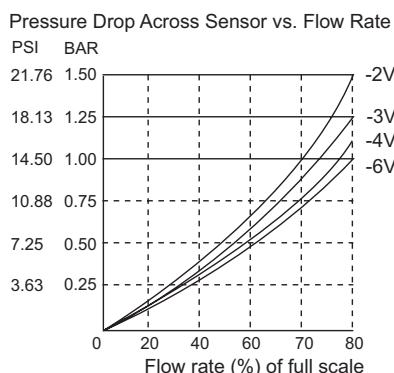

Wetted Materials

- Housing: PVDF
- Flow insert: PTFE
- Quad ring seal: FPM
- Rotor: PVDF
- Pipe thread adapters: PVDF
- Suitable for clean fluids only

Electrical

- Power: 5 to 24 VDC @ 10 mA max.
 Output type: Open-collector transistor, 10 mA max. sink

Max. pressure/temperature:

- 5.5 bar @ -30°C (80 psi @ -22°F)
- 5.5 bar @ 24°C (80 psi @ 75°F)
- 3 bar @ 120°C (45 psi @ 248°F)

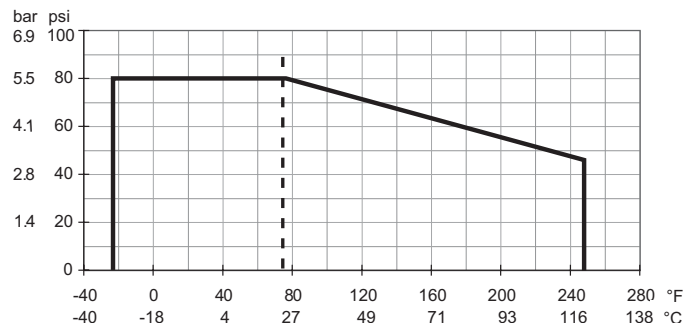

3. Installation

- The sensor may be installed in any position, although horizontal flow is recommended (the sensor mounted upright). If the sensor is not installed upright, the linearity error may be greater in the lower part of the sensor's measurement range.
- Mounting tabs are provided using #8 or M4 self-tapping screws (customer supplied). See Dimensions illustration for mounting tab hole pattern specifications.
- Install sensor with the arrow pointing in the direction of flow.
- Always maximize distance between the sensor and pump source. Never install immediately downstream of valves, fittings, etc. For optimum performance, a straight flow run of at least 100 to 150 mm (4 to 6 in.) should be provided before and after the sensor.
- Two pipe fitting adapters (included) convert the G 1/4 in. straight threads to 1/4 in. NPT pipe threads. **Hand tighten only!** Apply 1-2 turns of sealing tape to all threaded connections to prevent leaks.

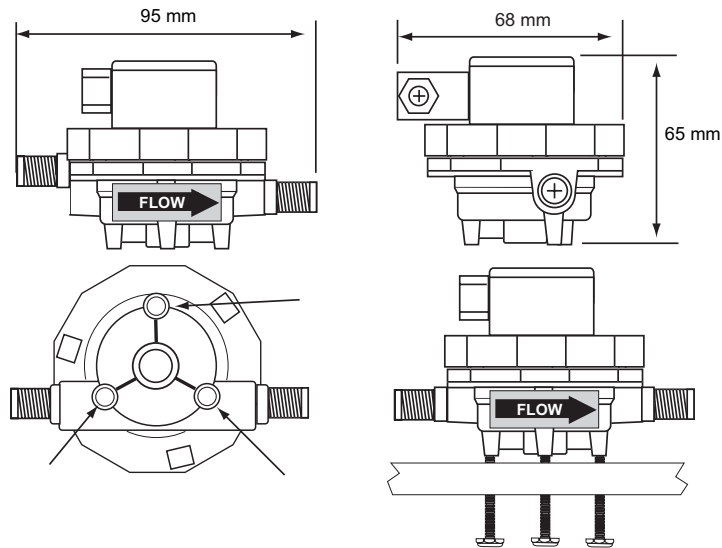

Installation Hints

- Avoid vibrations and shocks
- Avoid solids in the fluid
- Install a filter or line strainer upstream to protect sensor

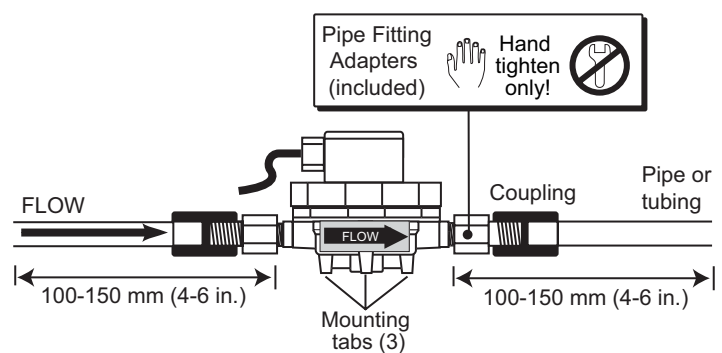

4. Wiring Details

Cable Extensions

- 2507 flowmeters distributed in the U.S. include 25 ft. of cable. The cable can be extended to 300 m (1000 ft.).
- Always maintain cable shield through cable splice.
- 2507 flowmeters distributed in Europe do not include cable. Refer to the sensor plug connection diagram (at right) for connection details.

Sensor plug connection diagram

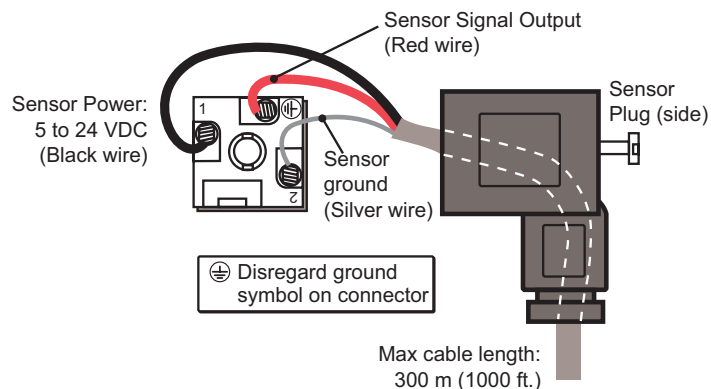

Instrument Connections

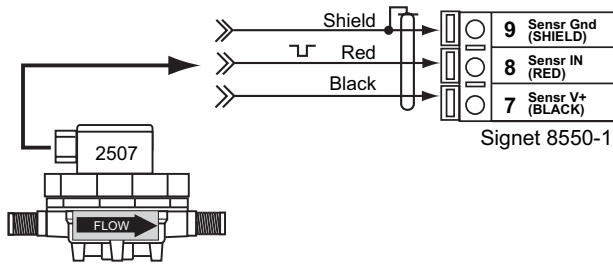

Signet 8900

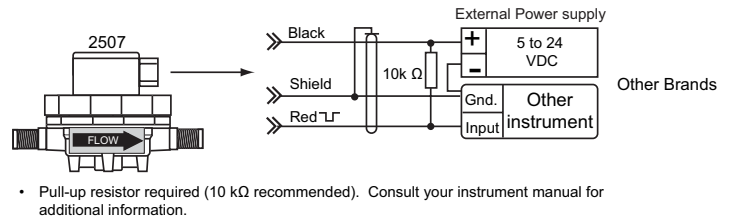
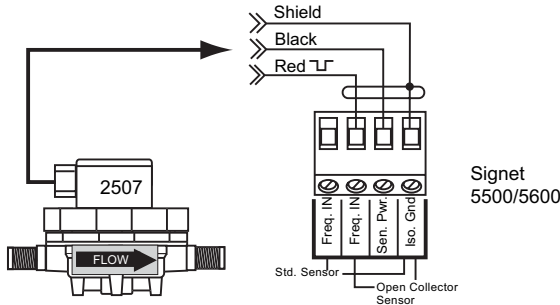
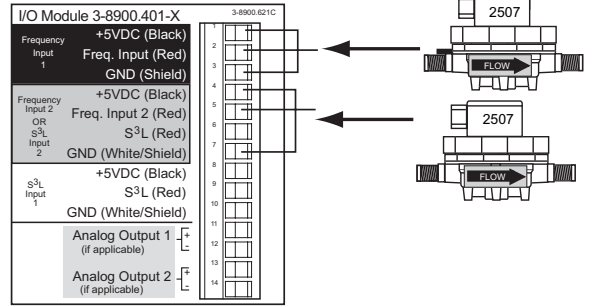

5. Calibration

The K-Factors listed here represent the number of pulses the sensor will generate for each measured engineering unit. They are listed in Liters and in U.S. gallons for each sensor model.

Sensor Model	Code	Flow Insert	K-FACTORS	
			Pulses per LITER	Pulses per U.S. Gallon
3-2507.100-1v	198 801 731	1mm	3413	12918
3-2507.100-2v	198 801 732	2mm	1687	6385
3-2507.100-3v	198 801 733	3mm	1045	3955
3-2507.100-4v	198 801 734	4mm	721	2729
3-2507.100-6v	198 801 736	NONE	382	1446

IMPORTANT!

- K-factors must be considered as approximate values.
- The number of pulses per volumetric unit may vary depending on the medium and the installation.
- For optimum performance, the system must be calibrated after installation.

6. Replacing The Flow Insert

Sensor range can be modified by changing the flow insert. The sensor must be removed from service and disassembled prior to installing the new flow insert. See section 2 specifications for flow range data.

Flow Insert Replacement Procedure:

1. Depressurize system and remove sensor.
2. Rotate the upper sensor body clockwise until it releases from the lower half, then lift off.
3. Remove rotor and quad ring seal from lower body.
4. Push the flow insert outward using a small screwdriver.
5. Install the new flow insert (small diameter inward) with the eraser end of a pencil. Apply light pressure until insert seats against the step in the lower body. **Do not force!**
6. Install rotor into lower body. Spin rotor with finger and check for free rotation. If rotor hits flow insert, remove rotor and push insert back until free rotor rotation is established. Use a rounded object like a pen or pencil body to adjust flow insert depth.
7. Install rotor, quad ring, and upper body. **Hand tighten only!** Do not overtighten upper body or the lower body assembly tabs will break.
8. Reprogram instrument with new K-Factor, see calibration section 5.

WARNING!

Do not use tools of any kind on the sensor body or port connections. Hand tighten only! Excessive force will damage sensor.

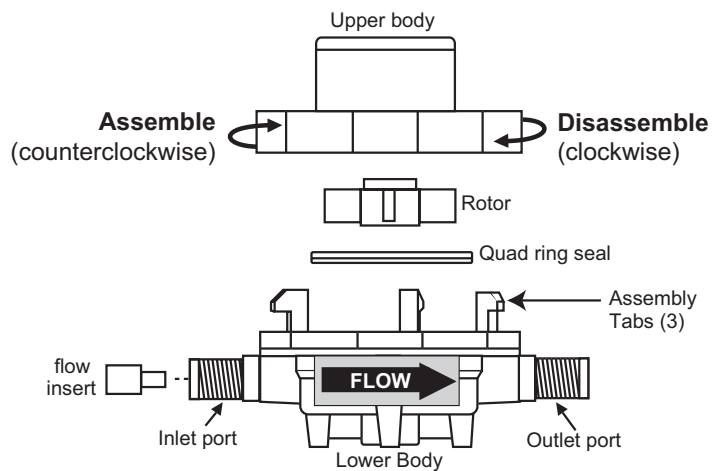

Ordering Information

Sensor Part Number		
3-2507.100	Mini-flow low flow sensor with free-running rotor	
↓	Insert option	
	-1V*	With 1 mm insert; for 100 to 2000 mL/m (0.026 to 0.528 gpm)
	-2V	With 2 mm insert; for 400 to 2800 mL/m (0.15 to 0.740 gpm)
	-3V	With 3 mm insert, for 700 to 4200 mL/m (0.185 to 1.123 gpm)
	-4V	With 4 mm insert, for 1300 to 6000 mL/m (0.343 to 1.585 gpm)
	-6V	With 6 mm inlet, no insert, for 3200 to 12000 mL/m (0.845 to 3.170 gpm)
	↓	
3-2507.100	-2V	Example Part Number *(-1V sensor available in Europe only)

Mfr. Part No.	Code
3-2507.100-1V	198 801 731 (-1V sensor available in Europe only)
3-2507.100-2V	198 801 732
3-2507.100-3V	198 801 733
3-2507.100-4V	198 801 734
3-2507.100-6V	198 801 736

Accessories and Replacement Parts

Mfr. Part No.	Code	Description
3-2507.080-2	198 801 550	Rotor, 2507
3-2507.080-3	198 801 547	Quad Ring, 2507
3-2507.080-5	198 801 508	DIN Connector, 2507
3-2507.081-1	198 801 548	1 mm Insert (available in Europe only)
3-2507.081-2	198 801 502	2 mm Insert
3-2507.081-3	198 801 503	3 mm Insert
3-2507.081-4	198 801 558	4 mm Insert
5523-0222	159 000 392	Cable, per foot